



AGRI



[mcveighparker.com](https://www.mcveighparker.com)

Keep up to date on all of
our Trade Shows and Events



About Us



A family business
working with you
since 1987



An internationally
recognised brand



1000+ products



Products available
through all major
Agri & Equine retailers



Dedicated Customer
Service Teams



PETE
Our polyethylene
range is recyclable
after use



@JFCAgri



John F. Concannon, Co-founder and CEO.

Water Supply

Contents

Water Supply

Small Capacity Drinkers.....	4
Large Capacity Drinkers.....	6
Fast-Fill Water Troughs.....	8
Insulated Water Troughs.....	9
Standard-Fill Water Troughs.....	10

Feeders & Feed Equipment

Evolution Automatic Calf Feeder.....	12
Milk Karts.....	14
Teat Feeders.....	16
Gate Feeders.....	19
Sheep Haybell.....	20
Feed Troughs.....	21
Feed Storage Bins.....	23
Feed Buckets.....	25

Housing & Accessories

Calf Hutches.....	27
Housing Accessories.....	28
Calf Isolation Unit.....	29

Wheelbarrows & ATV Equipment

Wheelbarrows.....	31
ATV Trailers & Accessories.....	33

Hygiene & Safety Products

Chemical & Medical Storage.....	37
Personnel Footbaths.....	38
Footbaths.....	39
Hoof Solutions.....	41
Stable Safe.....	42
Smart Farming Range.....	43
TidyWrap Recycling Bin.....	44
Other Hygiene & Safety Products.....	45

Equine Products

Feeders & Feed Equipment.....	47
Foal Feeders.....	50
Stable Equipment.....	51
Solar Lights.....	52

Spare Parts

Spare Parts.....	55
------------------	----



Small Capacity Drinkers

- Designed with rounded edges for ultimate animal safety.
- Crack resistant in extreme weather.
- Fitted with ½” brass valve.
- Unique double wall bowl making it extremely impact resistant.
- Mounting holes or brackets provided for secure fitting and easy installation.



Dumpy Tip-Over Drinker

CODE	CAPACITY	DIMENSIONS (MM)	COLOURS
DBL9	3.5L / 0.7gal	340 L x 230 W x 360 H	■ ■

- Gravity operated rotation, tips the water at 180 degrees dumping all the water and returning to a working position.
- Refills in 20 seconds at 3 bar pressure (9L/min) *max. 4 bar pressure.
- Float valve is fitted.
- Protected by an inbuilt galvanised steel bracket.



To view our product video scan this QR Code



Micro Drink Bowl

CODE	CAPACITY	DIMENSIONS (MM)	COLOURS
DBL4	4L / 0.9gal	330 L x 254 W x 228 H	■ ■

- Refills in 27 seconds at 3 bar pressure (9L/min) *max. 4 bar pressure.
- Built in drain-off plug (50mm).
- Optional left or right valve fitting.



Small Drink Bowl Protection Brackets

CODE	SUITABLE FOR
PB01	DBL4, DBL8, DBL8-H
PB02	DBL5, DBL7



PB01



PB02

Nose Fill Drink Bowl

CODE	CAPACITY	DIMENSIONS (MM)	COLOURS
DBL5	2L / 0.4gal	254 L x 254 W x 230 H	■ ■

- Refills in 8 seconds at 3 bar pressure (15L/min) *max. 4 bar pressure.
- Valve dispenses water on demand, suitable for wall fixing.



DBL5

Nose Fill Drink Bowl (Pipe Fix)

CODE	CAPACITY	DIMENSIONS (MM)	COLOURS
DBL7	2L / 0.4gal	270 L x 250 W x 225 H	■ ■

- Refills in 8 seconds at 3 bar pressure (15L/min) *max. 4 bar pressure.
- Valve dispenses water on demand, suitable for pipe fixing.



Nose Fill Drink Bowl (Double Entry Valve)

CODE	CAPACITY	DIMENSIONS (MM)
DBL8	2L / 0.4gal	300 L x 220 W x 260 H

- Refills in 24 seconds at 3 bar pressure (5L/min) *max. 4 bar pressure.
- Water supplied into the top or bottom of ball valve, suitable for wall fixing.



Heated Nose Fill Drink Bowl (Double Entry Valve)

CODE	CAPACITY	DIMENSIONS (MM)	ELECTRICAL INPUT
DBL8-H	2L / 0.4gal	300 L x 220 W x 260 H	24vDC

- Works in conditions as low as -30°C.
- Refills in 24 seconds at 3 bar pressure (5L/min) *max. 4 bar pressure.
- Water supplied into the top or bottom of ball valve, suitable for wall fixing.
- Low Safe Voltage - 24vDC.



Large Capacity Drinkers

- Designed with rounded edges for ultimate animal safety.
- Strategically positioned mounting holes or brackets are provided for secure fitting and ease of installation.
- Crack resistant in extreme weather.



To view our product video scan this QR Code

Thermal Drinker

Our Thermal Drinker prevents water from freezing during the winter, while also ensuring it stays cool in summer. The unique design can be used with or without an internal bucket. The float insulates the water by floating at the top of its surface and the animal accesses the water by nudging down on the float.



CODE	CAPACITY	DIMENSIONS (MM)
TED01	20L / 5gal	500 L x 490 W x 460 H

- *Freeze resistant up to
- 18 Hours in -5°C
 - 10 Hours in -15°C
 - 5 Hours in -20°C

*Results are based on using a full bucket of water at 15°C.

Conventional Drink Bowl

CODE	CAPACITY	DIMENSIONS (MM)	COLOURS
DBL	16L / 3.5gal	395 L x 400 W x 340 H	

- Fitted with ½" brass valve.
- Supplied with 2 stainless steel mounting brackets.
- Built in drain-off (25mm).
- Refills in 1 minute 36 seconds @ 3 bar pressure (10L/min)

*max. 4 bar pressure.



Fast-Fill Conventional Drink Bowl

CODE	CAPACITY	DIMENSIONS (MM)
DBLFF	16L / 3.5gal	395 L x 400 W x 340 H

- Fitted with ¾" brass valve.
- Supplied with 2 stainless steel mounting brackets.
- Built in drain-off (25mm).



Clean Drink Bowl

CODE	CAPACITY	DIMENSIONS (MM)
KDBL2	20.5L / 4.5gal	525 L x 375 W x 300 H

- Refills in 2 minutes 3 seconds @ 3 bar pressure (10L/min).
- Water covered by swinging lid to prevent contamination.



Corner Drink Bowl

CODE	CAPACITY	DIMENSIONS (MM)
DBL3	22L / 5gal	660 L x 482 W x 241 H

Refills in 4 minutes 24 seconds @ 3 bar pressure (5L/min).



Calf / Sheep Drink Bowl

CODE	CAPACITY	DIMENSIONS (MM)
DBL2	29.5L / 6.4gal	1250 L x 237 W x 235 H

- Refills in 6 minutes @ 3 bar pressure (10L/min).
- Can be placed between two zoned areas giving several animals simultaneous access to water.



Large Drink Bowl Protection Brackets

CODE	SUITABLE FOR
PB03	DBL, DBLFF

PB03



Fast-Fill Water Troughs

We understand the importance of providing livestock with fresh, clean and easily accessible drinking water. Through consultation with agricultural specialists and listening to the needs of farmers we have developed an extensive range of water troughs suitable for all applications.

- Valve protected within an easy to access compartment.
- Thick walls for greater strength and durability.
- Crack resistant in extreme weather.

Circular Fast-Fill Water Troughs

CODE	CAPACITY	DIMENSIONS (MM)
DT180FF	871L / 190gal	1550 Ø x 660 H
DT250FF	1125L / 248gal	1835 Ø x 680 H
DT350FF	1590L / 350gal	1900 Ø x 750 H
DT450FF	2046L / 450gal	2130 Ø x 830 H

Ingenious design reduces badger access.

DT450FF



Oval Fast-Fill Water Troughs

CODE	CAPACITY	DIMENSIONS (MM)
DT100FF	450L / 100gal	1550 L x 990 W x 685 H
DT600FF	600L / 130gal	1610 L x 1180 W x 840 H
DT800FF	800L / 175gal	1970 L x 1180 W x 840 H
DT1000FF	1000L / 220gal	2180 L x 1180 W x 840 H

Ingenious design deters badger access.

DT1000FF



Double Reservoir Fast-Fill Water Troughs

CODE	CAPACITY	DIMENSIONS (MM)
DT30FF	136L / 30gal	1250 L x 475 W x 310 H
DT90FF	400L / 88gal	1550 L x 730 W x 530 H

DT90FF



Mountable Water Trough

CODE	CAPACITY	DESCRIPTION	DIMENSIONS (MM)
DT80M	80L / 18gal	Without a valve	1000 L x 551 W x 447 H
DT80MFF	80L / 18gal	With Fast-Fill valve	1000 L x 551 W x 447 H

- Smooth edges for animal safety.
- Equipped with mounting holes, drain and easy to access float housing.



Single Reservoir Fast-Fill Water Troughs

CODE	CAPACITY	DIMENSIONS (MM)
DT15FF	68L / 15gal	700 L x 475 W x 310 H

- Fitted with a drain off bung for easy emptying and cleaning.
- Will withstand extreme climate conditions ensuring long life span.
- Valve protected within a plastic compartment with easy access for servicing.
- Provide your livestock with fresh, clean and easily accessible drinking water.



Insulated Water Troughs

Water will not freeze in sub-zero temperatures and will continue to work in conditions as low as -30°C without the need for electricity. Animals access the water by pushing down on the white float. The secure chamber can be easily accessed for servicing.

CODE	CAPACITY	DIMENSIONS (MM)
ID25	25L / 5.5gal	620 L x 560 W x 350 H
ID80	80L / 17.5gal	990 L x 597 W x 438 H
ID100	100L / 22gal	1100 L x 550 W x 645 H

ID80



Standard-Fill Water Troughs

Our troughs are tough, impact resistant and designed to withstand heavy use. We offer an extensive range of troughs available in a variety of shapes and sizes that are easy to transport, install and service.

- Thick walls for greater strength and durability.
- Crack resistant in extreme weather.

Single Reservoir Water Trough

CODE	CAPACITY	DIMENSIONS (MM)
DT10	53L / 12gal	685 L x 457 W x 255 H



Single Reservoir Corner Water Trough

CODE	CAPACITY	DIMENSIONS (MM)
DT27	100L / 22gal	940 L x 660 W x 335 H



Double Reservoir Water Troughs

CODE	CAPACITY	DIMENSIONS (MM)
DT20	100L / 22gal	900 L x 500 W x 430 H
DT40	180L / 40gal	1298 L x 472 W x 579 H
DT70	282L / 62gal	1372 L x 635 W x 451 H



DT40

Tip-Over Trough

CODE	DISCRIPTION	CAPACITY	DIMENSIONS (MM)
TOT1	Free Standing	100L / 22gal	2300 L x 685 W x 520 H
TOT2	Wall Mounted	100L / 22gal	2300 L x 685 W x 520 H

- Fitted with a float valve (36L/min) for quick refill after cleaning.
- Available with a floor or wall mounted galvanised steel frame.



TOT1

Feeders & Feed Equipment



Evolution - Automatic Calf Feeder



To view our product video scan this QR Code

Introducing the JFC Evolution Automatic Calf Feeder, the ideal solution for calf feeding. This innovative device automatically measures, mixes, and dispenses temperature-controlled milk to calves. It is programmed to cater to each calf's specific nutritional needs, promoting optimal growth. The self-cleaning cycle activates four times daily, ensuring hassle-free calf feeding.

The Evolution Range consists of a Control Unit and one or more Feed Stalls depending on your herd size. Calves are easily registered on the Control Unit using RFID technology and assigned to a predefined feed curve relative to their nutritional needs and your rearing objectives. Individual feeds are automatically dispensed and the system ensures no calf exceeds their allocated amount. Each calf's feed performance is consistently monitored on a user-friendly, 7-inch touch screen display and for ultimate convenience, this information is also available anytime, anywhere online or on the Evolution App.

The Evolution Automatic Calf Feeder can be fitted with an Additive Dispenser to distribute the precise amount to the relevant calves with accuracy and without additional labour. This makes the administration of electrolytes, probiotics, or any other additive effortlessly and stress free for both the calf and farmer.

S2 Control Unit

CODE	WEIGHT	DIMENSIONS (MM)
AF70	111kg	902 L x 680 W x 1263 H

- Feeds 2 calves simultaneously.
- Capacity to feed up to 70 calves.
- Ideal for small to medium herds.
- Single Hopper with capacity for 40kg of Calf Milk Replacer.



S4 Control Unit

CODE	WEIGHT	DIMENSIONS (MM)
AF01	132kg	902 L x 740 W x 1263 H

- Feeds 4 calves simultaneously.
- Capacity to feed up to 140 calves.
- Suitable for large and expanding herds.
- Dual Hopper with capacity for 2 x 30kg Calf Milk Replacer offers flexibility to feed 2 different types of milk simultaneously.



Feeder Stall

The Evolution has a working capacity of up to 4 Feed Stalls with each having a maximum range of up to 7m from the Control Unit. The Feed Stall can be easily cleaned to reduce build-up of dirt and bacteria.

CODE	WEIGHT	DIMENSIONS (MM)
ST01	46kg	1449 L x 510 W x 1000 H

- Anti-backing bar supports initial calf training onto the system.
- Robust, durable and easy to clean.
- A Teat Spray Cleanse (optional) cleans each teat after use for enhanced hygiene standards.



“JFC Evolution has not just saved us time.... it has saved us physically, mentally & financially.”

Ryan Russell - South Gloucestershire.

Milk Karts

Our Milk Karts (Generation 3) are CE Certified. Depending on your requirements the Manual (170L) and ATV (340L) Milk Karts are available with a Mixer, Pump, Mixer and Pump or neither. Built to last, they are manufactured with a galvanised steel frame.

These labour-saving devices provide consistently blended milk while reducing the separation of precious nutrients, and unnecessary foaming. The 170L model can mix a 20kg bag of milk replacer in just 4 minutes.

Mixer and Pump Milk Karts dispense up to 7,500L milk at 36L/min on a single battery charge.

- Easily transports bulk quantities of whole milk or milk replacer to calves.
- 1½" lever valve allows user to control the amount of milk dispensed.
- Twist on lid minimises spillages and contamination.
- Upgraded braked castor swivel wheels allow for smooth manoeuvrability.
- Non-corrosion plastic rim wheels for use on rough terrain.



Manual Milk Karts

DIMENSIONS (MM)	1180 L x 675 W x 1115 H
CAPACITY	170L
KART CODE	DESCRIPTION
MK1703	Milk Kart
MK170M3	Milk Kart + Motorised Mixer
MK170P3	Milk Kart + Pump
MK170MP3	Milk Kart + Motorised Mixer + Pump



To view our product video scan this QR Code

ATV Milk Karts

DIMENSIONS (MM)	1970 L x 1050 W x 1271 H
CAPACITY	340L
KART CODE	DESCRIPTION
A-MK340	ATV Milk Kart
A-MK340M3	ATV Milk Kart + Motorised Mixer
A-MK340P3	ATV Milk Kart + Pump
A-MK340MP3	ATV Milk Kart + Motorised Mixer + Pump



To view our product video scan this QR Code

Electric Milk Warmer & Collar

CODE	DESCRIPTION
E3000	3,000 Watt Milk Warmer (<i>heat 140L of water to 40°C in 2hrs</i>)
HL350-HC	E3000 collar for use with our ATV/Manual Milk Karts

- Easy to clean.
- High heating power band with step-less adjustable thermostat.
- Stainless steel stand pipe.
- Auto shut off when desired temperature is reached.
- Compatible with all of our Milk Karts / ATV Milk Karts.



Teat Feeders

Our Teat Feeders offer an efficient way of supplying milk to several animals at once. Each feeder is fitted with either an inverted or non-return valve teat to deliver milk by gravity feed. The teats encourage the natural sucking action allowing milk to be delivered to the animal at an optimum rate. Our Teat Feeders are fitted with 2 sturdy hooks for mounting on a standard gate or fence making them extremely versatile for use around the farm. Hygiene is of huge importance in the rearing of young animals and our Teat Feeders are hygienic, easy to clean, disinfect due to the smooth, seamless polythene surface. Our Teat Feeders are ideal for use in conjunction with our Calf Hutches.



To view our product video scan this QR Code

JFC Starter Teat (Blue)

CODE CT6

- Ideal for new born calves.
- The inverted nipple encourages the calf to suck thereby increasing saliva flow and enhancing milk digestion.
- This pull-through teat can be used on any feeder with a Ø22mm opening.



EazyFlow Teat

CODE CT9

- Specifically designed to replicate the natural sucking action of a calf on the udder.
- Fitted with a non-return valve preventing milk from flowing back into the feeder ensuring optimum delivery to the calf.
- Manufactured from natural rubber with a soft texture, but durable to last a complete calving season.
- This pull-through teat can be used on any feeder with a Ø22mm opening.



Insert teats with point facing upwards. It is recommended to replace teats after each calving season.

JFC Lamb Teat

CODE CT8

- Manufactured from natural rubber it has a soft texture but is sufficiently durable to last a complete lambing season.
- Openings on each side encourage the lamb to correctly place the teat in its mouth, thereby reducing leakage.
- This pull-through teat can be used on any feeder with a Ø20mm opening.

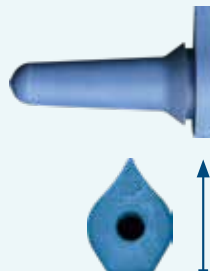

Insert teats with point facing upwards. It is recommended to replace teats after each lambing season.

Single Teat Feeder

CODE	CAPACITY	DIMENSIONS (MM)	TEAT
GF01	8L / 1.75gal	325 L x 290 W x 2440 H	Starter
GF01-CT8	8L / 1.75gal	325 L x 290 W x 240 H	Lamb Teat
GF01-CT9	8L / 1.75gal	325 L x 290 W x 240 H	EazyFlow



Four Teat Compartment Feeder

CODE	CAPACITY	DIMENSIONS (MM)	TEAT
GFC04	12L / 2gal*	705 L x 375 W x 355 H	Starter
GFC04-CT9	12L / 2gal*	705 L x 375 W x 355 H	EazyFlow

* Working Capacity.



Six Teat Reservoir Feeder

CODE	CAPACITY	DIMENSIONS (MM)	TEAT
GF06	30L / 6.5gal	832 L x 450 W x 330 H	Starter
GF06-CT8	30L / 6.5gal	832 L x 450 W x 330 H	Lamb Teat
GF06-CT9	30L / 6.5gal	832 L x 450 W x 330 H	EazyFlow



Six Teat Compartment Feeder

GFC06-CT9

CODE	CAPACITY	DIMENSIONS (MM)	TEAT
GFC06	18L / 4gal*	930 L x 355 W x 425 H	Starter
GFC06-CT9	18L / 4gal*	930 L x 355 W x 425 H	EazyFlow

* Working Capacity.



Ten Teat Reservoir Feeder

GF10-CT9

CODE	CAPACITY	DIMENSIONS (MM)	TEAT
GF10	50L / 11gal	914 L x 302 W x 508 H	Starter
GF10-CT8	50L / 11gal	914 L x 302 W x 508 H	Lamb Teat
GF10-CT9	50L / 11gal	914 L x 302 W x 508 H	EazyFlow



Ten Teat Compartment Feeder

GFC10-CT9

CODE	CAPACITY	DIMENSIONS (MM)	TEAT
GFC10	30L / 6.5gal*	1350 L x 550 W x 355 H	Starter
GFC10-CT9	30L / 6.5gal*	1350 L x 550 W x 355 H	EazyFlow

* Working Capacity.



Gate Feeders

Our Gate Feeders are suitable for cattle, sheep, equines, goats, and pigs. Made from durable polyethylene, they are impact-resistant and safe for animals. The smooth finish allows for easy cleaning and disinfection, maintaining hygiene standards.

Creep Feeder

CODE	CAPACITY	DIMENSIONS (MM)
CF150	60kg	1025 L x 600 W x 950 H

- Holds up to 3 (20kg) bags of meal.
- Fitted with 2 galvanised steel hanging brackets.



Mini Creep Feeder

CODE	CAPACITY	DIMENSIONS (MM)
CF80	40kg	790 L x 460 W x 710 H

- Holds up to 2 (20kg) bags of meal.
- Rear fill for farmer safety.
- Galvanised hanging brackets allows feeder to be moved easily.
- Fitted with bird flaps to reduce feed contamination.



Mini Hay Feeder

CODE	CAPACITY	DIMENSIONS (MM)
HF80	80L / 17gal	790 L x 460 W x 710 H

- Rear fill for farmer safety.
- Fitted with 2 galvanised steel hanging brackets.



Corner Gate Feed Trough

CODE	CAPACITY	DIMENSIONS (MM)	COLOURS
CGFT-1	10L / 2.2gal	385 L x 385 W x 250 H	■ ■

- Mounted between 2 gates at right angle to each other.
- Suitable for individual penning/hurdle systems where only one sheep is present in each pen/hurdle.



Slow Hay Feeder

CODE	CAPACITY	DIMENSIONS (MM)
SHF150	165L / 36gal	1025 L x 600 W x 950 H

- Fitted with 2 galvanised steel hanging brackets.
- Encourages slow feeding.



Gate Hay Feeder

CODE	CAPACITY	DIMENSIONS (MM)
GFH01	100L / 22gal	920 L x 430 W x 500 H

- Feeding partitions minimise hay wastage.
- Reinforced hooks fitted to give extra stability.



Gate Feed Trough

CODE	CAPACITY	DIMENSIONS (MM)
GFT1	23kg	711 L x 381 W x 304 H
GFT	46kg	1422 L x 381 W x 304 H



Sheep Haybells

Our Haybells for sheep are made from durable polyethylene, impact-resistant, and easy to move. The fracture-resistant material and rounded edge design prioritize animal safety. Coated with a smooth finish to prevent feed accumulation and simplify cleaning.



To view our product video scan this QR Code

Sheep Haybells

CODE	CAPACITY	NO. OF PORTS	DIMENSIONS (MM)
HB02	1 standard round hay bale	8	1850 Ø x 1500 H
HB04	3-4 small square bales.	6	1250 Ø x 1500 H

- Minimises wastage from trampling and fouling.
- Protects hay in all weather conditions.



Feed Troughs

Our range of Ground Feed Troughs minimise waste and can withstand severe impact.

Round Feed Trough

CODE	DIMENSIONS (MM)
RFL2	2133 Ø x 200 H

Can be bolted to a tractor tyre to provide a secure feeding platform (*tyre & M16 bolts not supplied*).



Round Feed Trough Insert

CODE	DIMENSIONS (MM)
RFL1	2133 Ø x 228 H

Acts as a meal feeder when inserted into a standard 20 space round feeder.



Ground Feed Troughs

CODE	CAPACITY	DIMENSIONS (MM)
FT3	15L / 3gal	1000 L x 300 W x 155 H
FT6	30L / 6.5gal	1854 L x 279 W x 127 H

Allows animals to feed from the ground in their natural feeding position.



Corri-Feed Troughs

CODE	CAPACITY	DIMENSIONS (MM)
CFT-225	40L / 9gal	2000 L x 225 W x 114 H
CFT-300	70L / 15gal	2000 L x 300 W x 152 H
CFT-375	110L / 24gal	2000 L x 375 W x 228 H



Basis Feeder

CODE	CAPACITY	DIMENSIONS (MM)
BF01	100kg	1000 L x 800 W x 340 H

The basis feeder features three compartments, allowing you to use a combination of minerals within the one feeder. The sloping outer walls ensure that animals don't tip or step on the basis feeder.



Rocker Feeder

CODE	CAPACITY	DIMENSIONS (MM)
MRF01	50kg	770 Ø x 880 H

The Mineral rocker supplement feeder has a self-raising function. The feeder always turns back to an upright position, no matter how much the animals push it around.



Supplement Feeding Station

Our Supplement Feeding Station protects expensive supplements from the elements. Animals lift the rubber cover with their heads allowing access to the supplements underneath. This product comprises three compartments, enabling a blend of different minerals. The inclined exterior walls prevent the product from being overturned by animals. Easily transported.

CODE	CAPACITY	DIMENSIONS (MM)
SFS01	40kg per compartment	1200 L x 1200 W x 880 H



Feed Storage Bins

Our Feed Storage Bins are ideally suited for storing feed on farmyards and in domestic situations. The bins can also be used to store salt, fuel, boots, wellingtons, sports equipment, etc outside your house whilst still protecting them from the weather. Ideal storage for solid fuel (wood, turf, briquettes). Can be transported with a forklift, bale handler or loader, the bin can be sited in close proximity to the feeding station thus reducing labour and time involved. The meal is kept clean and dry.

Standard Feed Storage Bins

CODE	CAPACITY	DIMENSIONS (MM)	COLOURS
SB100	100L / 22gal	660 L x 580 W x 540 H	■ ■
SB175	175L / 38.5gal	860 L x 860 W x 645 H	■ ■
SB350	350L / 77gal	1050 L x 975 W x 765 H	■ ■

- Weighted lid designed to remain securely closed.
- Can be locked if required.
- Stores and protects contents from harsh weather and pests.
- These bins can also be used for storing home fuels or grit.



SB175

Half Tonne Meal Bin

CODE	CAPACITY	DIMENSIONS (MM)
CMB1	600kg / 1000L	1200 L x 1200 W x 1360 H

- Wide opening at the top and a lockable lid.
- Fitted with drain-off (25mm) for ease of cleaning and emptying.
- Suitable for use with forklift, bale handler or loader.



One Tonne Meal Bin

CODE	CAPACITY	DIMENSIONS (MM)
CMB02	1200kg / 2000L	1080 L x 2000 W x 1360 H

- Perfect solution for transporting and storing meal on a farm.
- Suitable for use with forklift, bale handler or loader.
- 2 wide openings at the top and 2 independent lockable lids.
- Fitted with drain-off (25mm) for ease of cleaning and emptying.



Cubic Metre Meal Bin

CODE	CAPACITY	DIMENSIONS (MM)
CMB04	750kg / 1000L	1400 L x 1220 W x 960 H

- Fitted with drain-off (25mm) for ease of cleaning and emptying.
- Save money and time on each fill versus using bags.
- Easily tipped to allow access to feed at low levels.
- Fits in standard 8x4 car trailer.
- Bale handler entry points located at end of bin for ease of loading.
- Low profile for ease of access when filling or emptying.
- Strong and durable feed storage bin.



To view our product video scan this QR Code



Easy Empty Cubic Metre Meal Bin

CODE	CAPACITY	DIMENSIONS (MM)
CMB05	750kg / 1000L	1220 L x 1220 W x 1130 H

- Tilts for easy access.
- Smooth interior base without crevices, for ease of emptying with a standard bucket.
- Secure animal-proof lid with two rubber locking toggles.
- Hygienic, smooth interior surface and 25mm drain off valve for easy cleaning.



Feed Buckets

Double Buckets

CODE	DESCRIPTION	CAPACITY
DB1	Double Bucket	12L
DBB1	Bored Double Bucket	12L
DBB1-B	Galvanised wall bracket for DB1 / DBB1	



DB1

Multi Buckets

CODE	DESCRIPTION	CAPACITY
MB1	Multi Bucket	17L
MBB1	Bored Multi Bucket	17L
MBB1-B	Galvanised wall bracket for MB1 / MBB1	



MB1

Buckets

CODE	DESCRIPTION	CAPACITY
SB1	Green Bucket	9L / 2gal
SBB1	Green Bucket (bored)	9L / 2gal
SB2	Blue Bucket	5L / 1.25gal
SBB2	Blue Bucket (bored)	5L / 1.25gal
SB4	Black Bucket	12L / 2.6gal
SB5	Blue Bucket	9L / 2gal
SC3	Yellow Scooper Bucket	13.5L / 3gal
EQ61	Navy Flat-Sided Bucket	13.5L / 3gal
SB7	Low Side 3 Gallon Bucket	13.5L / 3gal



SB1



SB2

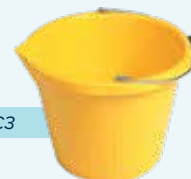

SC3



EQ61



SB4

Housing

& Accessories



Calf Hutches

Our Calf Hutches are strong, durable, weather resistant and UV stabilised. They are well ventilated, easy to clean and disinfect, helps reduce pneumonia, scours and Johne's disease. They support higher weaning weights, faster growth. A cost effective and an alternative to permanent buildings.

- Adjustable roof vent for ventilation.
- Lightweight and easy to handle.
- No planning permission required.



To view our product video scan this QR Code

Standard Single Calf Hutch

CODE	DIMENSIONS (MM)
BPCH	1651 L x 1270 W x 1270 H

Suitable for calves up to 8 weeks old.



Large Single Calf Hutch

CODE	DIMENSIONS (MM)
CH110	1956 L x 1320 W x 1448 H

Suitable for calves up to 12 weeks old.
Fitted with rear door, ideal for adding additional bedding.



Group Calf Hutch

CODE	DIMENSIONS (MM)
CH230	2100 L x 2150 W x 1700 H

Suitable for up to 4 calves.



Super Calf Hutch

CODE	DIMENSIONS (MM)
CH300	3404 L x 2184 W x 1925 H

Suitable for up to 8 calves or small ponies.



Check out our selection of Hutch Frames online @ uk.jfcagri.com

Housing Accessories

Calf Slat

CODE	DIMENSIONS (MM)	MAX LOAD
SL09-1	1200 L x 900 W x 120 H	1500kg/m ²

Our Calf Slats are tough, long lasting, easy to clean, handle, stack and maintain. They fit perfectly in group pens reducing the quantity of bedding required (when using bedding).

- Lower bedding costs.
- Weather resistant, can be used all year round.
- Durable and labour saving.
- Stacks for easy storage when not in use.
- Available in a pallet of 26.

SL09-1



Slat Divider

Our Calf Slat dividing system, is an ideal way to further reduce your bedding costs. The Slat Dividers are easily fitted to the JFC Agri Calf Slat, allowing for a flexible calf cubicle system. Following installation there is less trampling in the cubicle area, resulting in an additional saving on bedding costs.

CODE	DIMENSIONS (MM)
CSD02	1180 L x 105 W x 691 H

- Easy to clean / install.
- Reduces draughts and keeps the calf warmer.

CSD02



Calf Jacket

CODE	SIZE
CJ-00	Small / 65cm
CJ-01	Medium / 75cm
CJ-02	Large / 85cm



Our Calf Jackets are made from high quality material that is both water and tear resistant, with a rip-stop outer. Calf Jackets help maximise conversion of energy from feed to growth, rather than heat. They are ideal to help new born calves maintain body heat and reduce illnesses like pneumonia, due to cold stress in the early days of life. Fitted with strong buckles and rear leg straps, making sure they stay in place. Our Calf Jackets will help give your calves the best start in life.

- Breathable & water resistant material.
- Easy to fit and machine washable at 30°C.
- Maintains the calf's natural body temperature and protects from extreme weather.

Calf Isolation Unit

CODE	DIMENSIONS (MM)
IU-01	1460 L x 1020 W x 1200 H

Our Calf Isolation Unit is an individual calf housing unit which is ideal for the effective isolation of calves. The polyethylene body will ensure the calf is kept warm and draught-free. Lightweight, easy to disinfect, comes with a bracket, a removable calf slat for drainage and heat lamp (bulb not included). An additional removable tray underneath the unit ensures that all waste is contained and can be disposed of separately to comply with Farm Assurance Schemes. The unit provides for more effective feed monitoring, reduces bedding requirements and can help to lower calf mortality rates.

- Provides for specific needs of individual calves and more effective feed monitoring.
- Easy to clean, can be power hosed and disinfected in minutes.
- Reduces the spread of infection.
- Stacks for easy storage when not in use.

Animals under red lights should be monitored regularly.



IU-01

Wheelbarrows

& ATV Equipment



Wheelbarrows

Our range of innovative Wheelbarrows are ideal for Agricultural / Equine use. Each Wheelbarrow is fitted with a galvanised metal frame and roller bearing pneumatic wheels to deliver superior manoeuvrability and smooth handling. Our Wheelbarrows are tough, durable and lightweight in use, even with heavy loads.



To view our product video scan this QR Code

Tipping Wheelbarrows

CODE	CAPACITY	DIMENSIONS (MM)	COLOURS
TWB250	250L	1830 L x 860 W x 860 H	■ ■ ■
TWB400	400L	1800 L x 900 W x 950 H	■
TWB500	500L	2190 L x 1100 W x 910 H	■



- Minimum effort to transport and tip heavy bulky loads.

Mini Tipping Wheelbarrow

CODE	CAPACITY	DIMENSIONS (MM)	COLOURS
TWB125A-1	125L	1255 L x 590 W x 640 H	■



Our Mini Tipping Wheelbarrow is ideal for use on the farm or garden, it's tough, durable, lightweight and easy to use.

Junior Tipping Wheelbarrow*

Our Junior Tipping Wheelbarrow is ideal for your little helper, it is tough, durable and lightweight.

CODE	CAPACITY	DIMENSIONS (MM)	COLOURS
TWB125-1	125L	1120 L x 590 W x 640 H	■

- Tips with ease and good handling on rough terrain.
- Ideal for mucking out and gardening.

**Adult Supervision Recommended*



Slimline Feed Wheelbarrow

CODE	DESCRIPTION	CAPACITY	DIMENSIONS (MM)
TWB7	Narrow Wheelbarrow		
TWB7-PL	Plastic Lid for TWB7	250L	1200 L x 630 W x 800 H
TWB7-L	Hinged Lid for TWB7		
TWB7-D	Wooden Divider for TWB7		

The slim, narrow shape makes it particularly suited for narrow passageways in farm buildings and stables. Fitted with 2 pneumatic wheels and 2 swivel wheels for optimum manoeuvrability.

- 2 varieties of lids and a divider available separately.
- Large capacity makes it ideal for distributing feed in stables and sheds.
- Lightweight even with heavy loads reducing physical strain on the user.



TWB7

Fixed Body Swivel Wheelbarrow

CODE	CAPACITY	DIMENSIONS (MM)	COLOURS
TWB2-G	250L	1575 L x 865 W x 720 H	

- Fitted with a heavy duty 200mm swivel wheel.
- Suitable for use on level ground.



Fixed Body Wheelbarrow

CODE	CAPACITY	DIMENSIONS (MM)	COLOURS
TWBG	250L	1800 L x 865 W x 720 H	

This 250L wheelbarrow is fitted with a galvanised metal frame and roller bearing pneumatic wheels to deliver superior manoeuvrability and smooth handling. It is tough, durable and lightweight in use, even with heavy loads.

Also suitable for transporting new born calves and other smaller animals.



Wheelbarrow Covers

CODE	SUITABLE FOR
TWB250-C	TWB250
TWBG-C	TWBG



TWB250-C

Our waterproof Wheelbarrow Covers are ideal for protecting contents from snow, wind and rain.

ATV Trailers & Accessories

Our range of trailers and boxes are particularly suited for All-Terrain-Vehicles (ATV) or Quad bikes. Each trailer is fitted with 2 pneumatic wheels, galvanised chassis and an easy-to-use tipping mechanism. The heavy duty galvanised frame ensures the trailer is suited to harsh terrain. Some initial assembly is required. ATV range not suitable for highway use.

ATV Fertiliser Spreader

CODE	CAPACITY	DIMENSIONS (MM)	COLOURS
ATV-FS500M2	500L	1971 L x 1800 W x 1200 H	

Our Manual ATV Fertiliser Spreaders rate of spread and on/off of spreading can be controlled without leaving the driver's seat.

- Suitable for operation on sloping and mountainous terrain due to its low centre of gravity and wide wheelbase.
- Large hopper capable of transporting and spreading up to 500kg of most fertiliser types.
- Wide spreading capability - covers a width of 14m at 13km/hr.
- Robust galvanized and painted heavy duty frame for heavy-duty performance.



NEW PRODUCT

ATV Tipping assist Trailer

CODE	CAPACITY	FEATURES	DIMENSIONS (MM)	COLOURS
ATV500TA-BK	500L	Gas strut tipping	2195 L x 1354 W x 966 H	■
ATV500TALM-BK		Gas strut tipping with lights & mudguards	2195 L x 1354 W x 966 H	■

Our ATV Tipping Assist Trailer is fitted with two 4 Ply off road tyres, a galvanised chassis, with a gas strut tipping mechanism. The heavy duty galvanised frame for reinforced strength that ensures the trailer is suited to harsh terrain.



ATV500TA-BK

- A gas strut feature to aid tipping loads.
- Capable of handling heavy loads up to 500kg.
- Fitted with a lever ball hitch.
- Tough & durable polyethylene body.
- Protective steel plate on front lip of body prevents damage on impact.

ATV Trailers

CODE	CAPACITY	FEATURES	DIMENSIONS (MM)	COLOURS
ATV250	250L	Fitted with eyelet hitch (lever ball hitch fitted on request)	1700 L x 800 W x 780 H	■ ■ ■
ATV400	400L	Fitted with lever ball hitch	2200 L x 1200 W x 900 H	■
ATV500	500L	Metal support frame suitable for heavy loads. Fitted with lever ball hitch	2316 L x 1425 W x 940 H	■

- Lever ball, locking hitch.
- Spring loaded locking mechanism.
- Strong hinge point.
- Protective plate on tipping point.



ATV500-2



To view our product video scan this QR Code

ATV Hydraulic Tipping Trailer

CODE	CAPACITY	FEATURES	DIMENSIONS (MM)	COLOURS
ATV500T-3	500L	Fitted with an easy-to-use hydraulic tipping mechanism	2195 L x 1364 W x 966 H	■

- Reinforced heavy duty galvanized chassis.
- Tough & durable polyethylene body.
- Protective steel plate on front lip of body prevents damage on impact.
- Hydraulic tipping mechanism for tipping of loads (load capacity 500kg).
- Strengthened rugged axle complete with 4 Ply off road tyres and mud guards.
- Fitted with a lever ball hitch.



To view our product video scan this QR Code



ATV Carrier Box

CODE	CAPACITY	DIMENSIONS (MM)
ATV-CBD	200L / 43gal	810 L x 950 W x 650 H
ATV-CBS	150L / 32gal	810 L x 950 W x 385 H



ATV-CBD

ATV Carrier Box Lid

CODE	DIMENSIONS (MM)
ATV-CBL	710 L x 880 W x 100 H



Hygiene & Safety

Chemical & Medical Storage

Large Free-Standing Chemical Storage Cabinets

CODE	CAPACITY OVERALL	CAPACITY BUNDED	DIMENSIONS (MM)
SC-01	700L	125L	1220 L x 520 W x 1310 H
SC-02	380L	60L	685 L x 520 W x 1310 H

- Bund capacity safety feature to control any possible spillages.
- Fitted with 2 internal perforated rust-proof and chemical resistant shelves (load capacity up to 120kg).
- Manufactured from tough and durable polyethylene.
- Supplied with lock and key.
- Designed to safely store chemicals & medicines.
- Please note this storage cabinet is not suitable for storing pesticides or flammable liquids.
- Fitted with vent.



SC-02



SC-01

Wall Mountable Chemical Storage Cabinet

CODE	CAPACITY OVERALL	CAPACITY BUNDED	DIMENSIONS (MM)
SC-03	180L	16L	540 L x 435 W x 915 H

- Fitted with 2 aluminium shelves (load capacity 40kg).
- Manufactured from tough and durable polyethylene.
- Supplied with lock and key.
- Please note this storage cabinet is not suitable for storing pesticides or flammable liquids.
- Designed to safely store chemicals & medicines.
- Fitted with vent at side.



Medi-Safe Storage Cabinet

CODE	CAPACITY	DIMENSIONS (MM)
MS004	180L	540 L x 435 W x 915 H
MS001	117L	580 L x 390 W x 600 H

- Manufactured from tough and durable polyethylene.
- Supplied with lock and key.
- Designed to safely store medicines, documents & first aid supplies.
- Meets farm inspection requirements.
- Wall mountable.



MS004

Personnel Footbaths

Disinfectant Footbath

CODE	DIMENSIONS (MM)	COLOURS
FBP01	534 L x 305 W x 64 H	Green
FBP05	1000 L x 580 W x 55 H	Yellow

Position at the entrance to a shed/building to prevent the spread of disease/infection. Fitted with a foam pad insert to reduce the amount of solution required and avoid spillages.



FBP05

Footbaths

We offer an extensive range of footbaths which when used with good farming practices reduce the spread of infection and assist in the prevention and treatment of hoof diseases and lameness. These footbaths are manufactured from tough polyethylene making them extremely hard wearing and durable. All of our footbaths are designed with a turned in lip which significantly reduces the amount of solution wasted due to spillages.

Narrow Interlocking Smooth Base Footbath

CODE	CAPACITY	DIMENSIONS (MM)
FB7	150L / 33gal	2525 L x 690 W x 150 H

- Fits in standard crush.
- Interlocking joints for connecting multiple baths.
- Suitable for when a pre-wash is required prior to solution bathing.



Cattle Footbaths

Cattle Smooth Base Footbath

CODE	CAPACITY	DIMENSIONS (MM)
FB2	360L / 80gal	2450 L x 770 W x 216 H



Cattle Profiled Base Footbath

CODE	CAPACITY	DIMENSIONS (MM)
FB4	300L / 66gal	2095 L x 800 W x 216 H

- Profiled base opens hooves for extra penetration of solution.



Sheep Footbaths

Sheep Foam Footbath

CODE	CAPACITY	DIMENSIONS (MM)
FBF01	40L / 13gal	2380 L x 565 W x 45 H

- Designed for reducing the spread of infection, easy handling and cleaning.
- Reduces stress on animal.
- Minimises solution waste.



To view our product video scan this QR Code

Sheep Profiled Base Footbath

CODE	CAPACITY	DIMENSIONS (MM)
FB5	145L / 32gal	2451 L x 470 W x 203 H

- Profiled base opens hooves for extra penetration of solution.
- Interlocking joints for connecting multiple baths.
- Narrow shape makes it ideal for mobile sheep races.

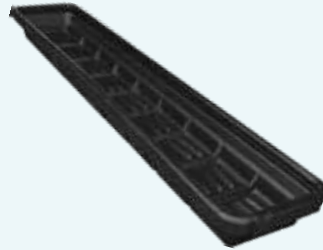

To view our product video scan this QR Code

Sheep Smooth Base Footbath

CODE	CAPACITY	DIMENSIONS (MM)
FB1	80L / 18gal	1540 L x 570 W x 140 H



To view our product video scan this QR Code

Narrow Sheep Foam Footbath

CODE	CAPACITY	DIMENSIONS (MM)
FBF01-330	Up to 40L / 8.5gal	2380 L x 330 W x 45 H

- Reduces splashing, therefore wastes less solution.
- Foam ensures hoof is fully penetrated in solution.
- Easily transported to desired location.
- Zero reflection on surface means no hesitation for sheep walking through.

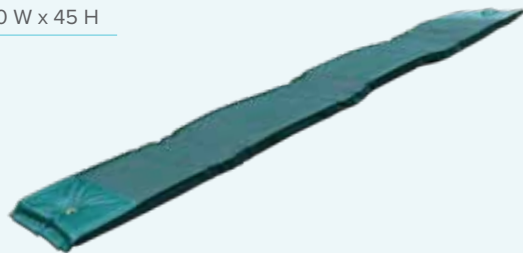

Hoof Solutions

Our range of Hoof Solutions certified by Organic Farmers and Growers are formulated with a blend of minerals, cleansers and natural antiseptic Tea Tree Oil, suitable for all of our Footbaths. When mixed with water they create an acidic solution (pH2) which maximises the availability of chelated minerals and acts as an effective treatment for digital dermatitis and other bacterial hoof ailments for cows and sheep.

Sheep Hoof Paste

CODE	CAPACITY	DIMENSIONS (MM)
HHSP5	500ml - Box of 10	190 Ø x 250 H

For pre-conditioning lambs hooves from birth. Apply the paste to each hoof as part of your new-born protection process.



Dairy Hoof Spray

CODE	CAPACITY	DIMENSIONS (MM)
HHDS5	500ml - Box of 10	218 Ø x 258 H

Our Dairy Hoof Spray is developed for direct contact applications to the cow's hoof. Apply to problem area daily along with regular foot bathing for best results.



Premium Dairy Hoof Solution

CODE	CAPACITY	DIMENSIONS (MM)
HHD20	20L	240 L x 290 W x 380 H
HHD200	200L	580 Ø x 880 H
HHD1000	1000L	1000 L x 1000 W x 1000 H

Provides 500 cow passes in a 200L Footbath.



All-In-One Sheep Hoof Solution

CODE	CAPACITY	DIMENSIONS (MM)
HHSAI120	20L	290 L x 240 W x 380 H
HHSAI200	200L	580 Ø x 880 H
HHSAI1000	1000L	1000 L x 1000 W x 1000 H

Provides 800 sheep passes in a 100L Footbath.



Stable Safe™



Stable Safe - Shine



CODE	CAPACITY
STABLESHINE	500ml

A highly effective, ready to use spray cleaner suitable for hard surfaces. Shine quickly removes stubborn dirt and debris from surfaces and leaves stables and horseboxes with a pleasant aroma. Perfect for cleaning your stable equipment, stall mats, floors, horseboxes, doors, worktops and paintwork.



Stable Safe - Shine Ultra



CODE	CAPACITY
STABLESHINEULTRA	1L

A highly effective, concentrated cleaner suitable for hard surfaces. Shine Ultra quickly removes stubborn dirt and debris from surfaces and leaves stables and horseboxes with a pleasant aroma. Once diluted Shine Ultra is suitable to be used with knapsack sprayers and pressure washers meaning it is ideal for large scale applications. Perfect for cleaning your stable equipment, stall mats, floors, horseboxes, doors, worktops and paintwork.



Stable Safe - Strength



CODE	CAPACITY
STABLESTRENGTH	50 tablets per pouch

DEFRA-approved for general and specific orders (including foot and mouth, swine vesicular and tuberculosis). Stable Strength tablets can be easily mixed with warm water and provides a quick and cost-effective way of disinfecting your equine environment.



Stable Safe - Scent



CODE	CAPACITY
STABLESCENT	500ml

A ready to use spray that will help your horse to relax and unwind when in the stable or transport. Scent will leave a herbaceous fragrance allowing your horse to feel calm and familiar with their surrounds. Ideal for removing unpleasant aromas within the equine environment.



Smart Farming Range

FarmCam HD allows you to monitor activity on the farm with a range of up to 1,250 metres. The camera features motion-detection and night-vision while recording Full HD (1920X1080) video and sound. Notifications and alarms are sent directly to your smartphone or PC with live view available on the move once the system is connected to WiFi. Comes with 3 year warranty. Connects up to 4 waterproof cameras. Storage capacity of 1TB.

FarmCam 360s

For indoor and outdoor use that can cover 360 degrees and can be powered by 230V or a Luda Farm solar panel during warmer months. The camera needs Wi-Fi/Internet access for set-up and live-view in the FarmCam 2.0 App which is free of charge. It has dual-band functionality. FarmCam 360S can record upon motion detection and sends you a notification in the App.

CODE	DESCRIPTION
LF-FC360S	FarmCam 360s

- 2560x1440 QHD video resolution with 16x digital zoom.
- Dual-band 2.4Ghz and 5Ghz functionality.
- Lens with a 122-degree field of view.



FarmCam Mobility S

CODE	DESCRIPTION
LF-FM01S	FarmCam Mobility S

- Use it wherever you have 3G/4G network coverage.
- SIM-card that automatically chooses the strongest network included.
- IP66 with camera skin applied.
- Smart heat and movement sensor with rechargeable battery (up to 2 months usage).



TidyWrap Recycling Bin

Ideal way to store waste plastic bale wraps. The bin is bottomless and has a removable lid which keeps the bale wraps clean and dry. When used effectively the bin can significantly reduce collection costs as the overall weight is much less than if the bale wraps were wet and contaminated. The TidyWrap is designed specifically to allow a bale wrap to be used as a liner saving on the cost of buying a new liner each time. Bungee cord supplied to secure the liner in place.

CODE	CAPACITY	DIMENSIONS (MM)
TRB1	120 plastic bale wraps*	1250 Ø x 1000 H

* Capacity depends on level of contamination and compaction.



The images above show how to cut strips into the bale which create four tie handles that form the liner. The liner is secured to the bin with a bungee cord (supplied). Once full the handles are tied together and the bin can be easily lifted from above leaving a full bale ready for collection.



Other Hygiene & Safety Products

Fuel / Salt Storage Bins

CODE	CAPACITY	DIMENSIONS (MM)
SB100	100L / 22gal	660 L x 580 W x 540 H
SB175	175L / 38.5gal	860 L x 860 W x 645 H
SB350	350L / 77gal	1050 L x 975 W x 765 H



- Stores and protects fuel / salt from harsh weather and pests.
- Suitable for locking if required.

Hazard Cones

CODE	DESCRIPTION	DIMENSIONS (MM)
YTC01	Blank Cone	
YTC02	Machinery Crossing	
YTC03	Silage Cutting	
YTC04	No Parking	
YTC05	Cows Crossing	
YTC06	Wet Floor	
YTC07	Hedge Cutting	
YTC08	Mud on Road	
YTC09	Horses Crossing	
YTC10	Sheep Crossing	

510 L x 400 W x 700 H



Feeders & Feed Equipment

We design feeders to care for and manage equines. We consult with veterinary experts and breeders to produce tough, impact-resistant products ensuring horse safety. Our products are durable and have a smooth, seamless finish for ease of cleaning.

Horse Haybell

CODE	DIMENSIONS (MM)
HB01	1850 Ø x 1500 H

- Minimises wastage due to trampling or fouling.
- Fits over a standard round bale.
- Delivers superior nutrition retention by minimising nutrient loss from exposure to weather.
- Designed with 4 feeding ports.
- Easy to manoeuvre in the paddock or field.



Mini Haybell

CODE	DIMENSIONS (MM)
HB03	1250 Ø x 1000 H

- Minimises wastage due to trampling and fouling.
- Protects hay in all weather conditions.
- It is designed with 3 feeding ports.
- Easy to manoeuvre.
- Holds 3-4 small square bales.



TearDrop Feeders

CODE	TDHF-C	TDHF-W
DESCRIPTION	Tear Drop Corner Hay Feeder	Tear Drop Wall Hay Feeder
CAPACITY	110L	50L
DIMENSIONS (MM)	865 L x 625 W x 600 H	550 L x 325 W x 650 H
COLOURS		



TDHF-W-2

- Very strong while also ensuring horse safety.
- Mounting holes to securely fit to a stable corner, wall or horse box.
- Easy fill opening.
- Designed specifically for the care & management of equines.

Circular Floor Feeder

CODE	CAPACITY	DIMENSIONS (MM)	COLOURS
EQ3	15L / 3.5gal	686 Ø x 229 H	



- Designed with an outer base rim to stabilise and prevent tipping.
- Internal compartment designed to be filled with sand or water to provide stability.
- Versatile feeder for indoor and outdoor use.



“I have always been an advocate of feeding concentrate from the floor. It is the natural grazing position, supports the work we do with training, stretching the top line and the long back muscles. It is all round a better, more natural way of feeding horses.”

Richard Davison,
Olympic Dressage Rider.

Square Floor Feeder

CODE	CAPACITY	DIMENSIONS (MM)	COLOURS
EQ4	10L / 2.2gal	475 L x 475 W x 165 H	



Wall Feeder

CODE	CAPACITY	DIMENSIONS (MM)	COLOURS
EQ1	15L / 3.5gal	390 L x 390 W x 220 H	



- 3 mounting holes for secure fixing to a wall or post.

Corner Feeder

CODE	CAPACITY	DIMENSIONS (MM)	COLOURS
EQ2	20L / 4.4gal	660 L x 419 W x 190 H	



- 4 mounting holes for secure fixing to a wall or post.

Door Mounted Swivel Feeder

CODE	CAPACITY	DIMENSIONS (MM)	COLOURS
EQ10	15L / 3.5gal	560 L x 305 W x 200 H	



- Ideal for stable doors with swivel feed slots.
- 3 mounting holes for secure fixing.

Foal Feeders

Foal Feeder

CODE	CAPACITY	DIMENSIONS (MM)	COLOURS
EQ5	12L / 2.5gal	370 L x 355 W x 200 H	



- Fitted with 2 mounting holes for secure fixing.
- Adjustable stainless steel bars prevent adult stock accessing the foal feed.

Ringfort Foal Feeder

CODE	WEIGHT	DIMENSIONS (MM)
FCF01	40kg	1300 L x 1300 W x 1180 H



Made to order

- Unique feeding system for feeding concentrate to foals.
- By adjusting the plate at the feeder port, each foal can be fed the appropriate amount of concentrate.
- Fitted with a ballast system which can be filled for additional stability.



Stable Equipment

Haysoaker

CODE	CAPACITY	DIMENSIONS (MM)
EQ9	300L / 66gal	1417 L x 850 W x 1031 H



- Large 1.5" quick drain-off.
- Easy open grate for submerging the hay.
- Easy manoeuvrable frame with lockable castor wheel.
- Fully galvanised frame for long lasting protection.

Mineral Lick Holder

CODE	DIMENSIONS (MM)	COLOURS
MLC01	305 L x 260 W x 260 H	



Playball

CODE	DIMENSIONS (MM)	COLOURS
P-BALL	225 Ø	



Made to order

Tack Box

CODE	CAPACITY	DIMENSIONS (MM)
EQ8	292L / 64gal	695 L x 530 W x 800 H



Solar Lights

Our solar lighting range is of superior build quality, features an IP65 waterproof rating and is suited for lighting larger areas. The full range comes with a five year warranty (one year on battery) for customer peace of mind.



Saber Solar Floodlight

CODE	BRIGHTNESS
SOLAR-01	40W / 4800LM

The Saber Solar Floodlight is self-sufficient powerful lighting. It has a long run time and can be set to auto or controlled with the remote control. The recommended installation height is 3-6m, with a detection distance of 8-12m.



Mini Saber Solar Floodlight

CODE	BRIGHTNESS
SOLAR-02	15W / 1600LM

The Mini Saber Solar Floodlight is ideal for someone who requires self-sufficient, automatic lighting in smaller areas. The recommended installation height is 2.4-5m with a detection distance of 8-12m.



Helios Solar Floodlight

CODE	BRIGHTNESS
SOLAR-03	30W / 4800LM

The Helios Solar Floodlight is the ideal solution for someone looking for flexible and self-sufficient lighting. The recommended installation height is 2-3m, with a detection distance 8-12m. The solar panel can be mounted up to 5m.



Flare Solar Brick Light

CODE	BRIGHTNESS
SOLAR-04	6W / 900LM

The Flare Solar Light is the ideal solution for someone wanting automatic lighting with easy installation and two lighting modes. The recommended installation height is 2-4m with a detection distance of 6m.

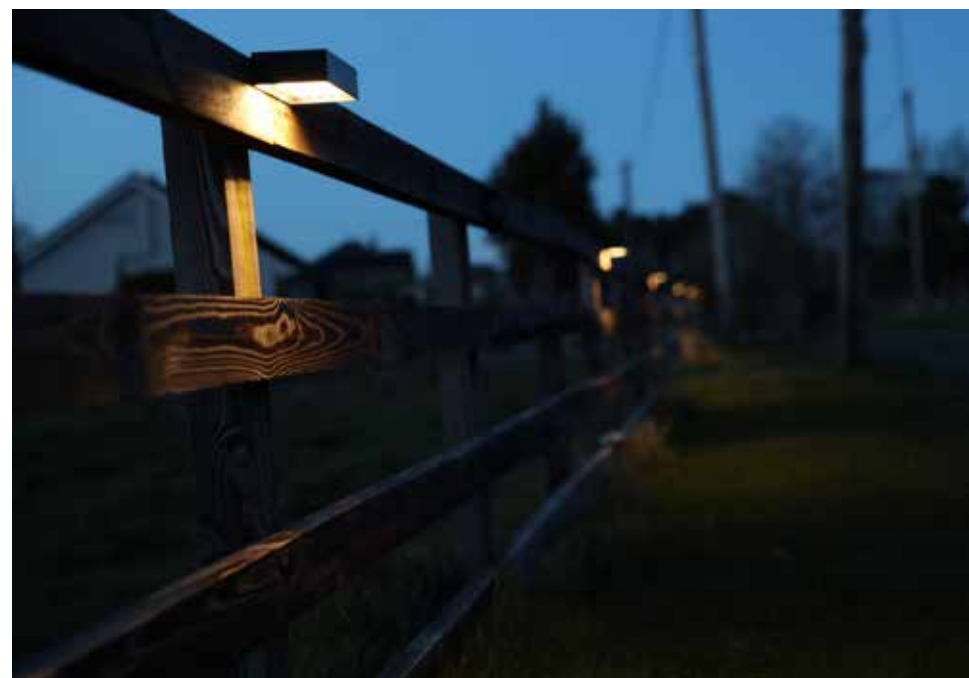

Spare Parts

Stay in Touch

Sign up to our Newsletter to be entered into our monthly draw to win a JFC AGRI fleece

Sign up at: jfcgroup.ie/enews/



To sign up scan this QR Code

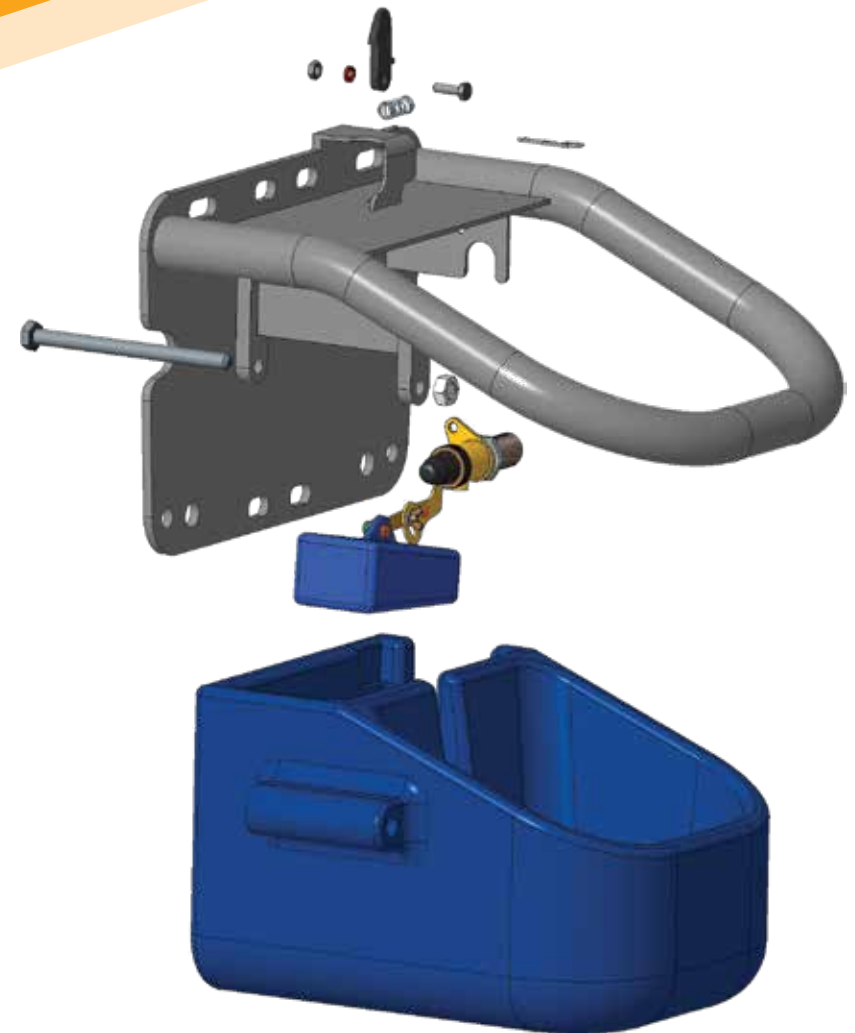































Milk Kart

















PRODUCT	CODE	DESCRIPTION	MK1703	MK170M3	MK170P3	MK170MP3	A-MK340	A-MK340M3	A-MK340P3	A-MK340MP3
	WBW3	Wheelbarrow wheel plastic rim 1" plain bearing	●	●	●	●				
	QW-WB	4 ply road wheel 18.00 / 9.50 - 8"					●	●	●	●
	CST10S	10" castor wheel	●	●	●	●				
	MK170-F	170L frame	●	●	●	●				
	MK340-AF	340L ATV frame					●	●	●	●
	MK170-B	170L bottle	●	●	●	●				
	MK340-B	340L bottle					●	●	●	●
	HL350	Geoline lid	●	●	●	●	●	●	●	●
	MG10W	10" plastic mudguard					●	●	●	●
	BV1-1/2"	1.5" valve	●	●	●	●	●	●	●	●
	DOF3	38mm / 1.5" drain off	●	●	●	●	●	●	●	●
	QHTC	Hitch					●	●	●	●
	JW	Jockey wheel FC240					●	●	●	●
	NGAM1B	Mixer motor		●		●		●		●
	MK-Seal-4mm	Milk Kart 4mm EPDM seal		●		●		●		●
	50840	JABSCO cyclone pump			●	●			●	●

Milk Kart











PRODUCT	CODE	DESCRIPTION	MK1703	MK170M3	MK170P3	MK170MP3	A-MK340	A-MK340M3	A-MK340P3	A-MK340MP3
	12V42AH	Lucas battery (AGM type)			●	●			●	●
	BC-12vDC	Numax battery charger			●	●			●	●
	19PHSW	1m 19mm clear PVC hose			●	●			●	●
	F00630000	Nozzle			●	●			●	●
	F0040710A	Piusi flow metre			●	●			●	●
	MK-ECM-3	Electrical control box M/O		●				●		
	MK-ECP-3	Electrical control box P/O			●				●	
	MK-EC-3	Electrical control box MP				●				●
	MK-EB-EP-LD	Control box extension lead (EU)		●		●		●		●
	MK-EB-LD	Control box extension lead (UK & IRL)		●		●		●		●
	MK-2MH	Hose (2m) with fittings			●	●			●	●
	MK-3MH	Hose (3m) with fittings			●	●			●	●
	MK-5MH	Hose (5m) with fittings			●	●			●	●
	CA100N	Control box switch		●	●	●		●	●	●
	MK-EC-F	10 AMP fuse			●	●			●	●
	MK-EC-FH	Control box fuse holder			●	●			●	●

PRODUCT	CODE	DESCRIPTION	DBL4	DBL5	DBL7	DBL8	DBL8-H	DBL9	DBL	DBLFF	KDBL2	DBL3	DBL2	TED01
	BVF1	4½" ball float							●	●			●	
	BVF3	Ball float									●			
	BV-MB	Opella valve (5L/min)	●									●		
	BV-DBL5	½" nose fill valve (15L/min)		●	●									
	JBV2	½" nose fill valve (5L/min)				●	●							
	JBV1	½" float valve (9L/min) - max 4 bar pressure	●					●						
	HFFSV20LS-JFC	Fast-flow valve								●				
	BV6B	½" valve (10L/min) with 6" arm									●			
	BV6B-B1	½" valve bent (10L/min)							●					
	BV6B-B3	½" valve (10L/min) with 6" bent arm											●	
	DOF1	25mm / 1" drain off							●	●	●	●	●	
	DOF4	50mm / 2" bung	●											●
	BC4	Blanking cap - on request	●											
	BC6	Plastic valve access cover							●	●		●	●	
	SP01	Polycarbonate plate	●											
	PRV16	Pressure reducing valve	●	●	●	●	●	●	●	●	●	●	●	
	DBL-BTB	Bracket x 2							●	●				
	DBL2-B	Bracket											●	
	KDB-B	Bracket x 2									●			



PRODUCT	CODE	DESCRIPTION	DT80M(FF)	DT15FF	DT30FF	DT90FF	DT100FF	DT600FF	DT800FF	DT1000FF	DT10	DT27	DT20	DT40	DT70	DT180FF	DT250FF	DT350FF	DT450FF	ID25	ID80	ID100	TED01
	BVF1	4½" ball float	●	●	●	●	●	●	●	●	●	●	●	●	●	●	●	●	●				
	BV3/8	¾" valve with ½" tail (36L/min)																		●	●	●	
	HFFSV20L-JFC	Fast-flow valve	●	●	●	●	●	●	●	●						●	●	●	●				
	HFFSV20LS-JFC	Fast-flow valve	●	●	●	●	●	●	●	●						●	●	●	●				
	BV6B	½" valve (10L/min) with 6" Arm									●	●		●									
	BV6B-B1	½" valve bent (10L/min) bend 1													●								
	BV6B-B3	½" valve (10L/min) with 6" bent arm											●										
	DOF1	25mm / 1" drain off		●	●	●	●									●	●	●					
	DOF3	38mm / 1.5" drain off																	●				
	DOF4	50mm / 2" bung																					●
	DOF7	75mm / 3" drain off	●					●	●	●										●	●	●	
	BC6	Valve access cover									●	●	●	●	●								
	TED01-BK	20L bucket																					●
	TED01-F	Floats x 2																					●

PRODUCT	CODE	DESCRIPTION	GFT1 \ GFT \ GFH01	CF80	CF150	GF01	GF01-CT9	GF01-CT8	GFC04	GFC04-CT9	GFC04-CT8	GF06	GF06-CT9	GF06-CT8	GFC06	GFC06-CT9	GFC06-CT8	GF10	GF10-CT9	GF10-CT8	GFC10	GFC10-CT9	GFC10-CT8	DBB1	MBB1	SBB1	SBB2	SBE2-B	ST01
	CF80-BF	Mini creep feeder PVC flaps		●																									
	CF150-PVC-S	Creep feeder PVC flaps			●																								
	GF06-H	Hook kit	●						●	●	●	●	●	●	●	●	●	●	●	●	●	●	●						
	GF01-H	Single teat feeder hooks				●	●	●																					
	CT6	JFC starter teat				●			●			●			●						●								
	CT6-10PK	JFC starter teat - 10 pack				●			●			●			●						●								
	CT50	JFC starter teat - box of 50				●			●			●			●						●								
	CT9	JFC eazyflow teat					●			●			●			●					●								
	CT9-10PK	JFC eazyflow teat - 10 pack					●			●			●			●					●								
	CT9-50	JFC eazyflow teat - box of 50					●			●			●			●					●								
	CT8	JFC lamb teat						●			●			●			●				●								
	CT8-10PK	JFC lamb teat - 10 Pack						●			●			●			●				●								
	AF-TE202	2mm Evolution teat - 4 Pack																											●
	AF-TE204	4mm Evolution teat - 4 Pack																											●
	CT1	Rubber calf teat																						●	●	●	●	●	
	CTV	Calf teat valve																						●	●	●	●	●	
	CTC	Calf teat with valve																						●	●	●	●	●	









Storage Units

PRODUCT	CODE	DESCRIPTION	AI1	EQ8	SC-01	SC-02	SC-03	MS001 NEW	MS004
	L2	Lock & keys	●	●					
	K1	Keys for L2 lock	●	●					
	CHEM-LK	Storage cabinet lock			●	●			
	SC01-K	Storage cabinet keys			●	●			
	SLL	Lock & keys					●	●	●
	MS004-K	Keys for SLL lock					●	●	●
	MS004-S	Aluminium shelf					●	●	●
	SC-02-S	Aluminium shelf				●			
	GRP01	38mm square mesh shelf			●				
	DOF1	25mm / 1" drain off			●	●			











Ground Feeders

PRODUCT	CODE	DESCRIPTION	CFT-225	CFT-300	CFT-375
	CFT-225E	225mm Corri-Feed end cap	●		
	CFT-300E	300mm Corri-Feed end cap		●	
	CFT-375E	375mm Corri-Feed end cap			●
	DBH	Lifting handle			●









Wheelbarrows

PRODUCT	CODE	DESCRIPTION	TWB250	TWB400	TWB500	TWBG	TWB2-G	TWB7	TWB125(A)
	WBW	4 ply wheelbarrow wheel 4.80 / 4.00 - 8" (as standard)	●	●	●	●	●	●	
	WBW1	6 ply wheelbarrow wheel 4.80 / 4.00 - 8" (on request)	●	●	●	●	●	●	
	WBW2	Puncture proof wheel 4.80 / 4.00 - 8" (on request)	●	●	●	●	●	●	
	WBW4	Puncture proof wheel 20mm bore 75mm hub length							●
	CST3	6" nylon castor wheel						●	
	CST8	8" rubber castor wheel					●		
	HWB	Handle grips	●	●	●	●			
	HWB1	Handle grips							●
	WBK	Fixing Kit				●			
	TWB250K	Fixing Kit	●						

ATV Trailers

PRODUCT	CODE	DESCRIPTION	ATV250	ATV400	ATV500	ATV1200	ATV1200R	ATV500T	ATV-FS500M	ATV500TA(LM)-BK
	WBW	4 ply wheelbarrow wheel 4.80 / 4.00 - 8" (as standard)	●							
	WBW1	6 ply wheelbarrow wheel 4.80 / 4.00 - 8" (on request)	●							
	WBW2	Puncture proof wheel 4.80 / 4.00 - 8" (on request)	●							
	QW-WB	4 ply road wheel 18.00 / 9.50 - 8"		●						
	QW	4 ply road wheel 20.00 / 10.00 - 8"			●	●	●	●		●
	QHTC	Hitch		●	●	●	●	●		●
	ATV-FS500E-WHL	Left wheel							●	
	ATV-FS500M-WH	Right wheel							●	
	MG10W	Mudguard						●	●	●
	ATV-500-TL	ATV Lights								●



Calf Housing

PRODUCT	CODE	DESCRIPTION	BPCH	CH1102	CH230	CH300	SCH2	IU-01
	CHVC-G	Hutch vent cover (Green)	●					
	CHVC-W	Hutch vent cover (White)		●	●	●		
	OT-L	Hutch rear access door (White)		●				
	RB-B	Bucket bracket for SB2					●	
	IU-01-BKB	Bucket bracket for SBB2						●
	SB2	5L / 1.25gal bucket Blue					●	
	SBB2	5L / 1.25gal bucket (bored) Blue					●	
	IU-01-LP	Lamp						●
	IU-01-BK	Bracket						●





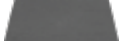



Storage Bins

PRODUCT	CODE	DESCRIPTION	CMB1	CMB2	CMB4	CMB5
	DOF1	25mm / 1" drain off	●	●	●	●
	CMB4-L	Lid for CMB4			●	
	RL75	Toggle for CMB4			●	
	CMB1-L	Lid for CMB1 / CMB2	●	●		
	CMB4-P	Pin for CMB4			●	
	CMB5-L	Lid for CMB5				●

Footbaths

PRODUCT	CODE	DESCRIPTION	FBP01	FBP05
	FB-F	Foam insert	●	
	FB-F3	Foam insert		●

Equine

PRODUCT	CODE	DESCRIPTION	EQ1	EQ2	EQ3	EQ5	EQ9	EQ10	TDHF-W
	DOF1	25mm / 1" drain off						●	
	DOF2	13mm / .5" drain off	●	●		●			
	DOF3	38mm / 1.5" drain off					●		
	DOF4	50mm / 2" bung			●				
	TDHF-W-FB	TearDrop wall bracket							●
	BV1-1/2"	1.5" valve					●		
	WBW	4 ply wheelbarrow wheel 4.80 / 4.00 - 8" (as standard)					●		
	CST10S	10" castor wheel					●		

McVeigh Parker stock a vast range of JFC products – If not in stock, we can order.

Contact us for more details



McVeigh Parker has eight nationwide branches all staffed by experienced teams offering great advice and customer service

Berkshire

Southend, Bradfield,
Reading, RG7 6HA
Tel: 01189 744777
Email: berks@mcveighparker.co.uk

Cambridge

Caxton Depot, Ermine Street,
Caxton, CB23 3PG
Tel: 01954 714110
Email: cambs@mcveighparker.co.uk

Devon

Muxbeare Lane, Uffculme, Cullompton,
Devon, EX15 3BY
Tel: 01884 824486
Email: devon@mcveighparker.co.uk

Kent

Thornden Farm, Lenham Road,
Headcorn, TN27 9LH
Tel: 01622 891095
Email: kent@mcveighparker.co.uk

Lancashire

Park Lane Industrial Estate, Wigan Road,
Ashton-in-Makerfield, Wigan, WN4 0BZ
Tel: 01942 725523
Email: lancs@mcveighparker.co.uk

Scotland

Market Road, Biggar,
Lanarkshire, ML12 6FX
Tel: 01899 221150
Email: scotland@mcveighparker.co.uk

Sussex

Stane Street,
Billingshurst, RH14 9JR
Tel: 01403 784250
Email: sussex@mcveighparker.co.uk

Worcestershire

Unit 16, Wilden Lane Industrial Estate,
Stourport on Severn, DY13 9JY
Tel: 01299 826111
Email: worcs@mcveighparker.co.uk

Keep up to date on
all of **our videos**



Follow us on YouTube!





AGRI

It is believed that the information given in this publication is correct, however products marketed by JFC AGRI are subject to continuous development and the company therefore reserve the right to alter information without notice. Errors and Omissions.

© 2024 All rights reserved.

For further details contact your nearest branch



[mcveighparker.com](https://www.mcveighparker.com)



@JFCAgri